

INDUSTRIAL THERMOCOUPLES

Base Metal Thermocouple (Bare Elements) With Ceramic Insulators

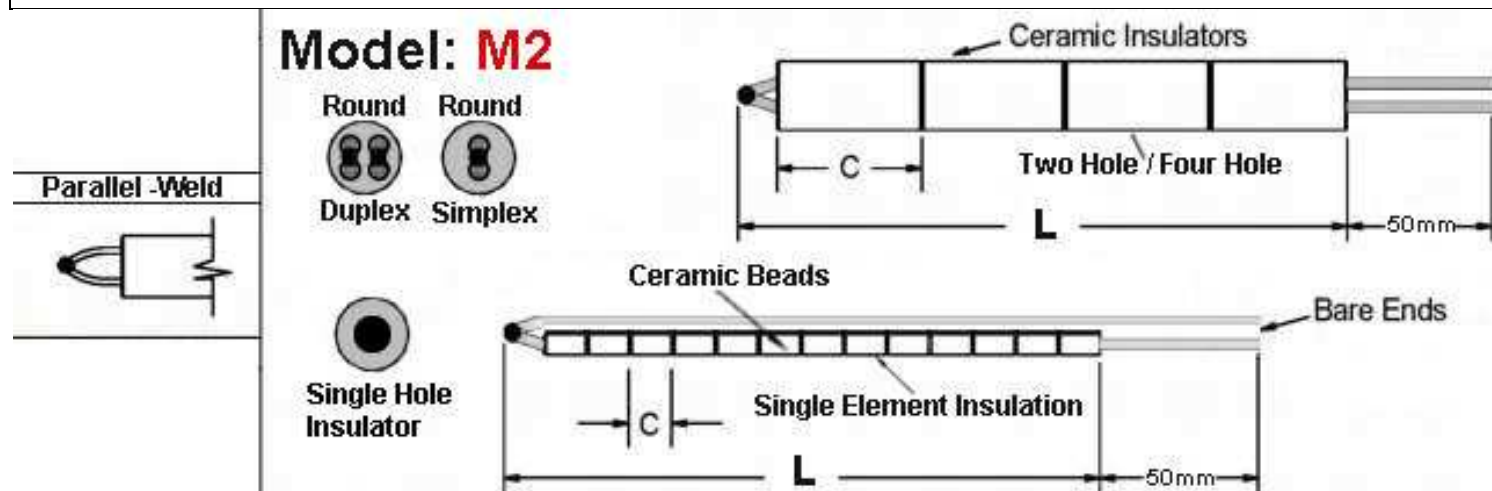

Configuration

1	Junction Weld Description
A	Parallel - Weld

2	Calibration	
	Standard Limits of Error	ACCURACY
A	J	0.75%
B	K	500°C + - 3°C / Above 0.75%

3	"L" Dimension
	Specify "L" Length In mm

4	Wire Dia. & Ceramic Insulator Selection				
Model	Wire Dia.	C. Insulator O.D.	Shape	"C" Length	Elements
1	1.6 mm	8.5 mm	Round	25 mm	Simplex /Duplex
2	1.6 mm	9 mm	Round	25 mm	Simplex /Duplex
3	2 mm	9.5 mm	Round	25 mm	Simplex /Duplex
4	2 mm	11 mm	Round	25 mm	Simplex /Duplex
5	2 mm	12 mm	Round	25 mm	Simplex /Duplex
6	2.5 mm	12.5 mm	Round	25 mm	Simplex /Duplex
7	2.5 mm	13.5 mm	Round	25 mm	Simplex /Duplex
8	3.2mm	13.5 mm	Round	25 mm	Simplex /Duplex
9	1.6 mm	4 mm	Ceramic Beads	25 mm	Simplex
10	2 mm	5 mm	Ceramic Beads	25 mm	Simplex
11	2.5 mm	5 mm	Ceramic Beads	25 mm	Simplex
12	3.2 mm	6 mm	Ceramic Beads	25 mm	Simplex